

## OVERHAULING A SUSPENSION UNIT

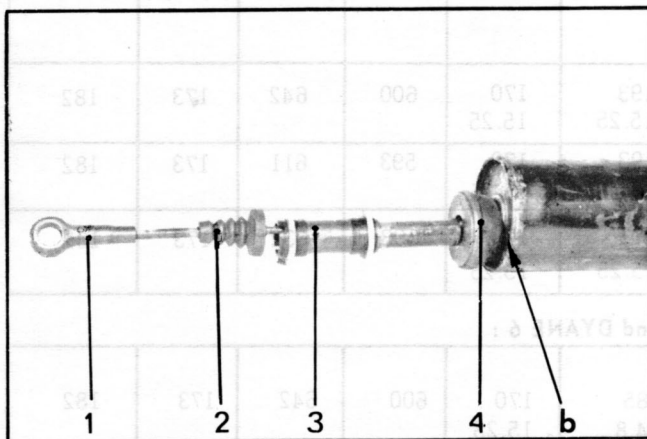
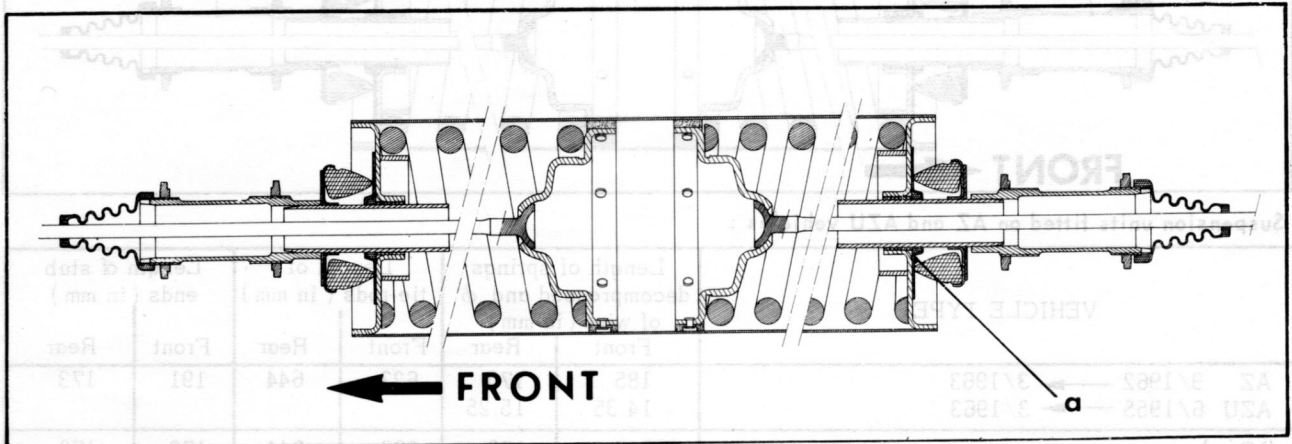

## REMOVAL

1. Unscrew the knife-edge end-pieces (1) from the front and rear tie-rods.

Free :

- the duct covers (2),
- the adjustable end-piece (3),
- the two rubber suspension buffers (4).

2. Using a scribe, mark the angular position of the front closing cup of the housing in relation to the latter.

Remove, for preference by grinding, the weld seam at point « b » securing the closing cup on the cylinder housing. (If milling is not possible hold pot in vice, tightening moderately, and saw weld seam ).

3. Free the assembly :

- front tie-rod (5),
- front closing cup (6),
- front suspension spring (7),
- compression cup (8).

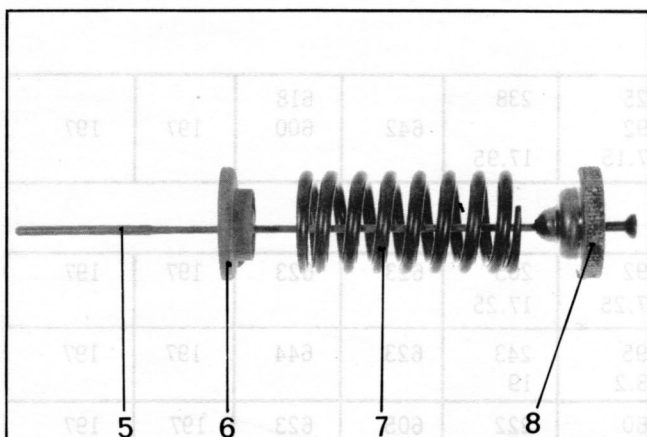

4. Free the assembly :

- rear tie rod,
- compression cup,
- rear suspension spring.

Remove, if necessary, the felt joints and the bronze bushes at « a ».

5. Clean all the parts.

6. Prepare the closing cups :

If bushes at « a » are to be replaced, soak the new bushes in mineral oil for approximately 24 hours.

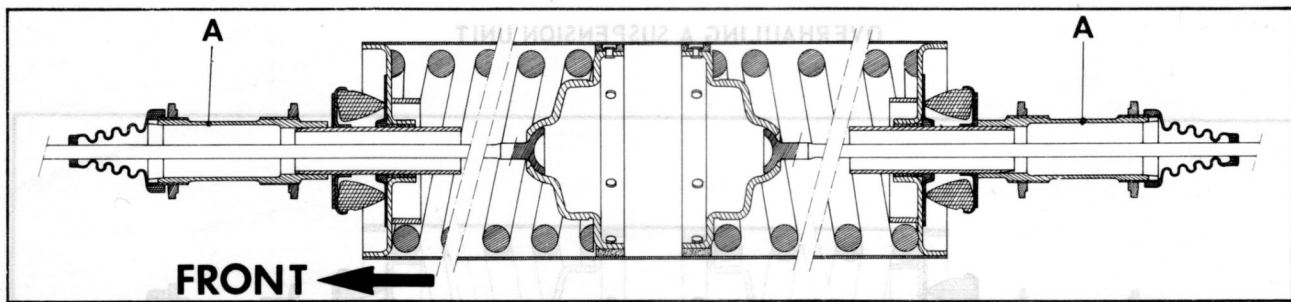

Suspension units fitted on AZ and AZU vehicles :

VEHICLE TYPE	Length of springs decompressed and $\phi$ of wire (in mm)		Length of tie-rods (in mm)		Length of stub ends (in mm)	
	Front	Rear	Front	Rear	Front	Rear
AZ 9/1962 → 3/1963 AZU 6/1955 → 3/1963	185 14.35	170 15.25	623	644	191	173
AZ } AZU } 3/1963 → 9/1965	185 14.8	170 15.25	600	644	173	173
AZ 9/1965 → 2/1970 AZU 9/1965 → 9/1972	185 14.8	170 15.25	600	642	173	182
AZ (2 CV 4) AZ (2 CV 6) } 2/1970 → 10/1971						
AZ (2 CV 4) AZ (2 CV 6) } 10/1971 → 9/1972	193 15.25	170 15.25	600	642	173	182
AZU 9/1972 →	193 15.25	170 15.25	593	611	173	182
AZ (2 CV 4) AZ (2 CV 6) } 9/1972 →	193 15.25	170 15.25	593	632	173	182

Suspension units fitted on DYANE vehicles - DYANE 4 and DYANE 6 :

AYA 8/1967 → 3/1968 AYA 2 3/1968 → 10/1968 AYA 3 1/1968 → 10/1968 AYB 10/1968 → 12/1968	185 14.8	170 15.25	600	642	173	182
AYA 2 10/1968 → AYB 12/1968 → 9/1972	193 15.25	170 15.25	600	642	173	182
AYA } AYB } 9/1972 →	193 15.25	170 15.25	593	632	173	182

Suspension units fitted on AK vehicles :

AK All Types 9/1962 → 5/1968 5/1968 → 7/1976	225 192 17.15	238 17.95	642	618 600	197	197
---	---------------------	--------------	-----	------------	-----	-----

Suspension units fitted on AM vehicles :

AM → 3/1969	192 17.25	205 17.25	623	623	197	197
AMB → 6/1972	195 18.2	243 19	623	644	197	197
AM 3/1969 → 6/1972	160 18.2	222 18.65	605	623	197	197
AM 6/1972 → 7/1976	160 18.2	222 18.65	575	611	197	197
AMB 6/1972 → 7/1976	160 18.2	222 18.65	611	632	197	197

\* Suspensions without interaction :

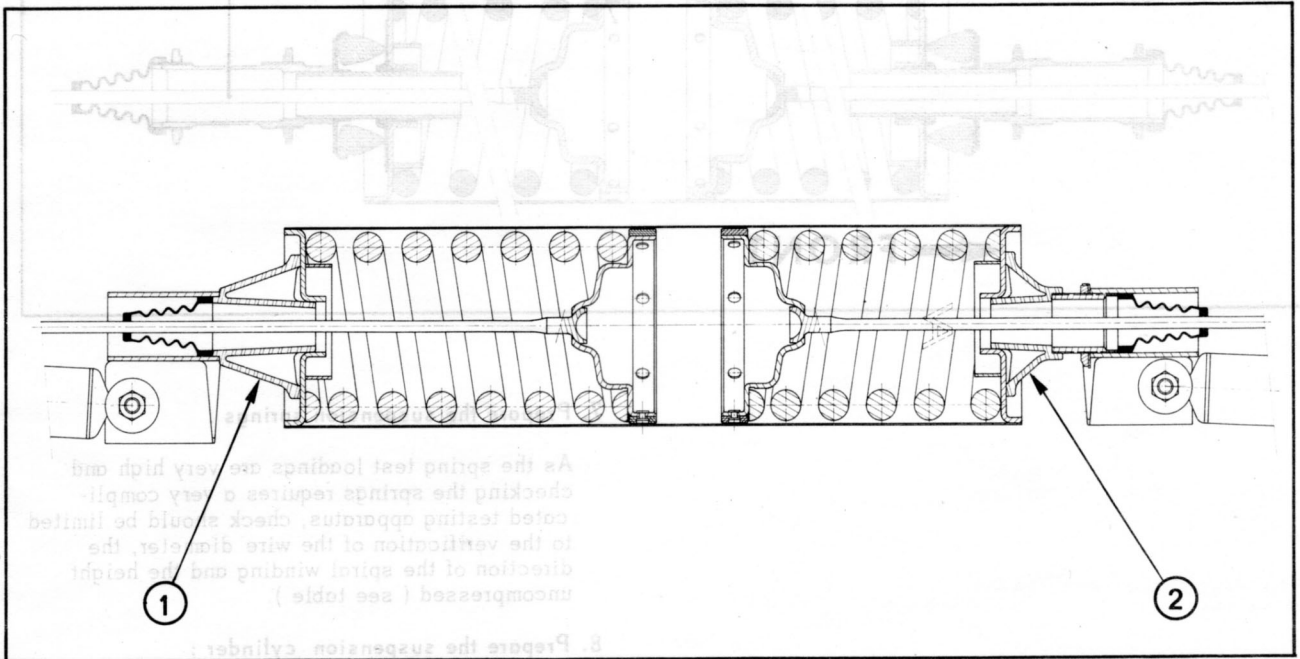

VEHICLE TYPE	Length of springs decompressed ( in mm )		Length of tie-rods ( in mm )	
	Front	Rear	Front	Rear
<b>Suspension units fitted on AM vehicles :</b>				
AM 3 7/1976 →	172 18	210.45 17.95	590	608
AMF 3 } AMC 3 } 7/1976 →	172 18	239.7 18.65	575	629

**Suspension units fitted on AK vehicles :**

AK 7/1976 →	168 17.15	260 17.15	575	608
-------------	--------------	--------------	-----	-----

**Suspension units fitted on AYCD ( ACADIANE ) vehicles :**

	168 17.15	260 17.15	590	792
--	--------------	--------------	-----	-----

\* The suspension unit is secured by positioning two spacers ① and ② between the unit and the brackets on sidemembers.

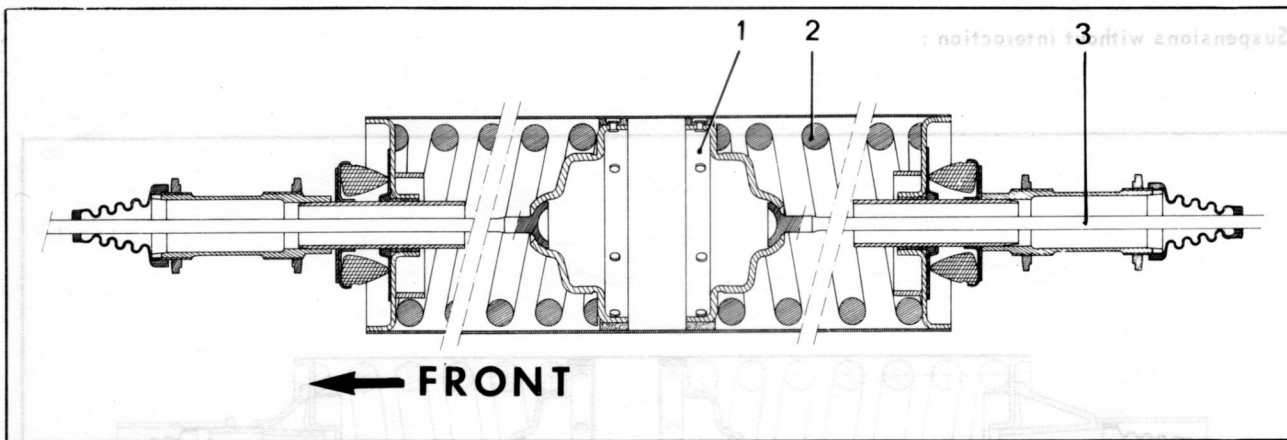

**7. Prepare the suspension springs :**

As the spring test loadings are very high and checking the springs requires a very complicated testing apparatus, check should be limited to the verification of the wire diameter, the direction of the spiral winding and the height uncompressed ( see table ).

**8. Prepare the suspension cylinder :**

Smear the interior using only castor oil.

**9. Prepare the compression cups ( 1 ) :**

Impregnate them with castor oil by immersion in a bath at an ambient temperature of workshop for 15 minutes, then leave them to drip.

**10. Prepare the tie rods :**

Identification ( see table ).  
Grease the balls ends ( TOTAL MULTIS grease ).

**11. Fit the suspension cylinder :**

- a) Place in position in the casing :
  - the rear suspension spring ( 2 ),  
( *right-hand spiral winding* ),
  - the compression cup ( 1 ),
  - the rear tie-rod ( 3 ).

- b) Place on the front tie-rod ( 4 ) :
  - the compression cup ( 7 ),
  - the front suspension spring ( 6 )  
( *left-hand spiral winding* ),
  - the front closing cup ( 5 ).

Insert the assembly in the casing.

PL. 576

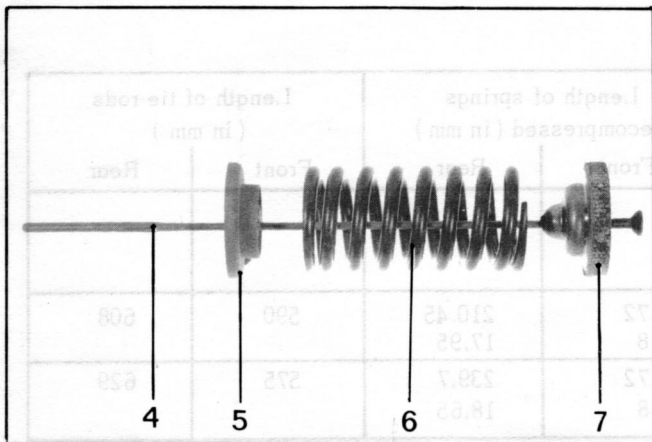

\* The suspension unit is secured by positioning two spacers ( 1 ) and ( 2 ) between the unit and the brackets on side-members.

PL. 51

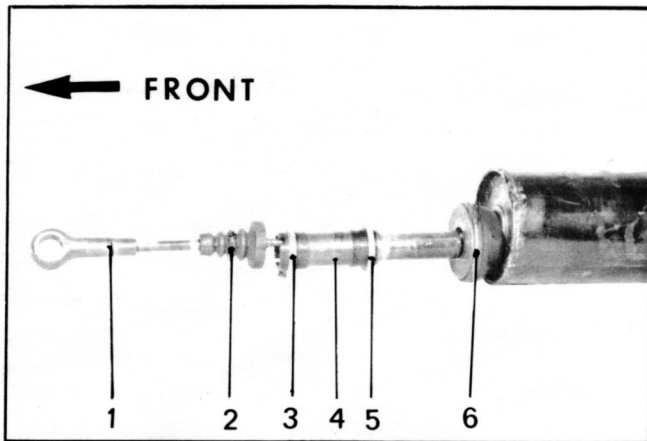
**12. Weld the front closing cup :**

- a) Locate the cup in position marked when removing.  
Ensure that the cup is perpendicular to the centre line of the casing.
- b) Arc weld or if not possible, weld with a blow torch.

**13. Assemble the suspension unit :**

Position in succession :

- a) On the front tie-rod :
  - the rubber suspension buffer (6),
  - the nut (5),
  - the adjustable end-piece (4) ( see table ) fitted with the nut (3),
  - the dust cover (2),
  - the end-piece (1) for carrying the knife edged pin
- b) On the rear tie-rod :
  - the rubber suspension buffer (12),
  - the nut (11),
  - the adjustable end-piece (10) ( see table ) fitted with the nut (9),
  - the dust cover (8),
  - the end-piece (7) carrying the knife edged pin.

PL. 51

